

BLAUPUNKT

User manual



Enjoy it.

Headset

Safety Precautions

Read these safety instructions before using your device and store them for possible future reference.

- The device is not intended for use by persons (including children) with reduced physical, sensory or mental capacity. Persons who have not read the manual, unless they have received explanations by a person responsible for their safety and supervision should not use this unit.
- Children should be monitored to ensure that they do not play with the device.
- The device should always be readily accessible.
- The device should not be exposed to dripping or splashing water.
- No objects filled with liquids such as vases shall be placed on the device.
- Always leave a minimum distance of 10 cm around the unit to ensure sufficient ventilation.
- Open flame sources, such as candles, should not be placed on top of the device.
- The device is intended for use only in a temperate climate.
- At full volume, prolonged listening to the portable audio device may damage the user's hearing and cause hearing troubles (temporary or permanent deafness, hearing drone, tinnitus, hyperacusis).
- So we recommend not to listen to the portable audio device at high audio volume and no more than one hour per day at medium audio volume.
- CAUTION: Danger of explosion if battery is incorrectly replaced or not replaced by the same type or equivalent.
- The battery should not be exposed to excessive heat such as sunshine, fire or similar.
- Different types of batteries, new and used batteries should not be mixed.
- The battery must be installed according to the polarity.
- If the battery is worn, it must be removed from the product.
- The battery must be disposed of safely. Always use the collection bins provided (check with your dealer) to protect the environment.
- The battery can't be replaced by the user, but only by the maker of this product, the after sales department or a qualified person.

SWITCH OFF IN RESTRICTED AREAS

Switch the device off where the use of the device is not allowed or where there is a risk of causing interference or danger, for example on board an aircraft, near medical equipment, fuel, chemicals or blasting sites.

ROAD SAFETY COMES FIRST

Check the current laws and regulations regarding the use of this device in the areas where you drive.

- Do not handle the device when driving.
- Concentrate fully on the driving
- Radio signals could affect some of the car's electronic systems such as the audio stereo and alarm systems.

INTERFERENCE

All wireless devices are susceptible to interference which may affect their performance. All our device conform to international standards and regulations, and if need be national ones, with a view to limiting user exposure to electromagnetic fields. These standards and regulations were adopted after the completion of extensive scientific research. This research established no link between the use of the mobile headset and any adverse effects on health if the device is used in accordance with standard practices.

AUTHORISED PERSONNEL

Only qualified people are authorized to install or repair this product.

ACCESSORIES

Only use batteries, chargers and other accessories which are compatible with this equipment. Do not connect incompatible products.

KEEP THE EQUIPMENT DRY

This equipment is not water proof. Keep it dry.

CHILDREN

Keep your device in a safe place, out of the reach of young children. The device contains small parts that may present a choking hazard.

Specifications

Rated voltage: DC 5V \equiv 1A

Max consumption: 5W

Radio frequency: 2.402-2.480GHz

Frequency range: 20Hz-20KHz

Sound power: 0.5mW

Max RF output : 1.40mW

Po Li-ion battery 350mAh

Bluetooth compatible version: 5.0

Working range : 10m

Charging time: 2.5 hours

Using time : 20 hours

Standby time : 90 hours

Dimension : 160 x 80 x 190mm

Weight : 172g

Description of the product

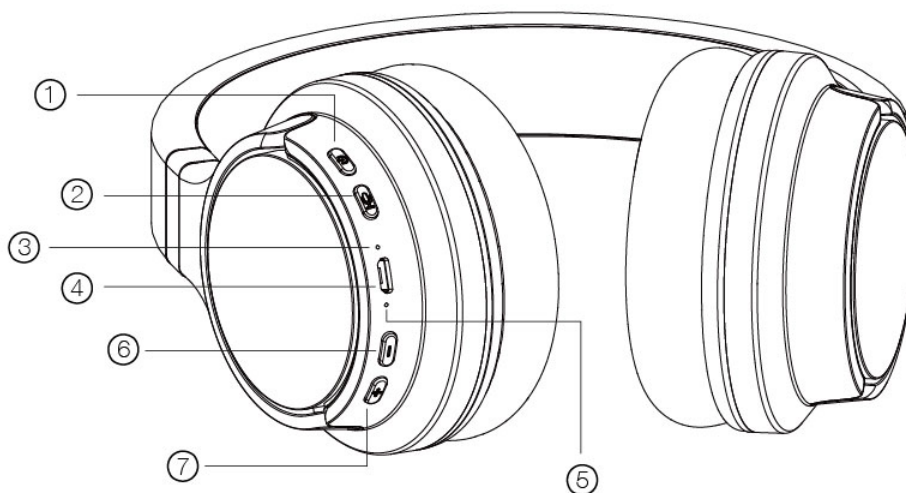

- 1- Press & Hold (3 Sec) : Power On
Press & Hold (4 Sec) : Power Off
Play/Pause, Answer/End Calls
Double Click : Re-dial Last Number
Press & Hold (1-2 Sec) :Reject Incoming Call
- 2- Voice assistant

- 3- Led indicator
- 4- USB charging port
- 5- Microphone
- 6- Previous track / Volume down
- 7- Next track / Volume up

How to use

Charge it

- On the right earcup, carefully plug the micro USB cable into micro USB charging port. and connect the other end of the cable to either a computer USB port or to a USB-compatible car or wall charger.

- Solid red LED light will appear to indicate when the headphone is charging.
- When charging is complete, the LED light will turn Blue.
- Charging time is approximately 2.5 hours.

Turn it On / Off

- Press & hold the power button on the right side of the headphone for about 4 seconds until the LED indicator light turns on.
- Press & hold the power button again for 3 seconds until the LED light turns off.

Button Function

- Press & Hold + area (refer to product Diagram) to turn up the volume
- Press & Hold – area (refer to product Diagram) to turn down the volume.
- Press + area (refer to product Diagram) to next track.
- Press – area (refer to product Diagram) to previous track.
- Press  area (refer to product Diagram) to Voice Assistant.

Bluetooth Pairing

Pair & connect with new device

Power on the wireless Bluetooth headphone (refer to the “Turn It On” section). To pair the headphone with a new device, the blue LED light blink to indicate it is ready to be paired with your device.

On your Bluetooth-enabled smartphone, tablet or media player, navigate to the Bluetooth settings menu, turn on the Bluetooth feature, and search for new devices After a few seconds you will see “BLP4120” listed.

Tap this model to select it. Solid blue LED light indicate your device has successfully paired.

With your previously paired device’s Bluetooth turned on and in range, the headphone will automatically reconnect to the last Bluetooth device it was connected to.

NOTE: If the headphone is not used within 5 minutes, the headphones will automatically turn off to save battery.

Play

- Connect your device to the headphone via Bluetooth (refer to the “Pair & Connect” section) Open your favorite music app and press play.
- Control the music, track & volume from your device, or control the music & volume. Press the Power button once to play/pause music & answer calls, press it twice to redial the last number called on your phone and press & hold it to reject an incoming call.
- All audio, including music, games, videos and notifications will be routed through the headphone.

Declaration of conformity UE

Dag Technologie®, hereby declares that this equipment conforms to the essential requirements and other relevant provisions of Directive 2014/53/UE. The declaration of Conformity can be viewed at the following address:

http://www.mms-support.net/OTA/ECD_DAG_BLP4120-003.pdf

The European directive 2012/19/EU on Waste Electrical and Electronic Equipment (WEEE), requires that old household electrical appliances must not be disposed of in the normal unsorted municipal waste stream. Old appliances must be collected separately in order to optimize the recovery and recycling of the materials they contain, and reduce the impact on human health and the environment. The crossed out "wheeled bin" symbol on the product reminds you of your obligation, that when you dispose of the appliance, it must be separately collected.



To avoid possible hearing damage, do not listen at high audio volume for long periods of time.

Imported by Dag Technologie®
79/81 Ancienne route Nationale 7
69570 Dardilly
France
www.blaupunkt.com

Enjoy it.

Dag Technologie®
79/81 Ancienne Route Nationale 7
69570 Dardilly – France